



QDD30S/45S

Electric Tractor 3.0/4.5t

Electronic Power Steering Makes Operation Easy & Fast;
Maintenance-free AC Driving Motor Offers Stronger Power, Making it More Cost-effective;
Slowing-down in Curved Pathway Ensures the Smoothness and Stability.

EP EQUIPMENT CO.,LTD
www.ep-equipment.com

FEATURE

Performance

- The innovative AC system offers strong power, accurate control, excellent performance.
- High strength vertical gearbox, longer working life.
- AMP connector and durable electric wires greatly reduce malfunctions of components.
- Sturdy load wheel ensures stability.



Safety

- Safety foot switch avoids operators from misoperation.
- Automatic braking and reverse current braking when foot switch is off or travel switch is neutral.
- Emergency disconnecter will cut off power source to avoid accident when truck goes out of control.
- Anti-rolling back brake keeps the truck from skidding down when truck is out of control or travelling on ramp.
- Dual-monitoring power steering.

Operation

- With the new design of ergonomical tiller head, all buttons can be reached conveniently & comfortably.
- With backrest cushion, spacious operation room and vibration absorber pedal, the operator feels more comfortable.
- Side-open battery compartment design for easy replacement and maintenance.
- Electric power steering, smooth & comfortable (EPS).

Maintenance

- AC traction motor, maintenance free.
- Hour meter and battery indicator will remind the operator of charging.
- Easily remove the back cover by only losing two bolts; Access to all key components for inspection, maintenance and replacement.
- Vertical motor makes the inspection & service much more convenient.
- Control system allows easy trouble-shooting.
- Low voltage lift cut off design protects the battery.

Electric tractor 3.0/4.5t QDD30S/45S

| Distinguishing mark | | | | | |
|---------------------|---|---------------------------------|-------|-----------------------|-----------------------|
| 1.1 | Manufacturer | | | EP | EP |
| 1.2 | Model designation | | | QDD30S | QDD45S |
| 1.3 | Drive unit | | | Electrics | Electrics |
| 1.4 | Operator type | | | Standing | Standing |
| 1.5 | rated capacity | Q | t | 3 | 4.5 |
| 1.7 | Rated drawbar pull | F | N | 600 | 900 |
| 1.9 | Wheelbase | y (mm) | mm | 975 | 975 |
| Weight | | | | | |
| 2.1 | Service weight (include battery) | | kg | 760 | 850 |
| 2.2 | Axle loading, laden driving side/loading side | | | / | / |
| 2.3 | Axle loading, unladen driving side/loading side | | kg | 480 / 280 | 530 / 320 |
| Types, Chassis | | | | | |
| 3.1 | Tyre type driving wheels/loading wheels | | | PU/PU | PU/PU |
| 3.2 | Tyre size, driving wheels (diameter×width) | | mm | Φ230x90 | Φ230x90 |
| 3.3 | Tyre size, loading wheels (diameter×width) | | mm | 2x Φ204x76 | 2x Φ204x76 |
| 3.5 | Wheels, number driving/loading (x=drive wheels) | | mm | 1x+ 2/2 | 1x+ 2/2 |
| 3.6 | Track width, front, driving side | b ₁₀ (mm) | mm | / | / |
| 3.7 | Track width, rear, loading side | b ₁₁ (mm) | mm | 708 | 708 |
| Dimensions | | | | | |
| 4.8 | standing height | h ₇ (mm) | mm | 166 | 166 |
| 4.9 | Height drawbar in driving position min./max. | h ₁₄ (mm) | mm | 1220 | 1220 |
| 4.12 | Tow coupling height scope | h ₁₀ (mm) | mm | 188 / 233 / 277 / 322 | 188 / 233 / 277 / 322 |
| 4.19 | Overall length | l ₁ (mm) | mm | 1282 | 1282 |
| 4.21 | Overall width | b ₁ / b ₂ | mm | 800 | 800 |
| 4.32 | Ground clearance, center of wheelbase | m ₂ (mm) | mm | 66 | 66 |
| 4.35 | Turning radius | W _a (mm) | mm | 1168 | 1168 |
| Performance data | | | | | |
| 5.1 | Travel speed, laden/ unladen | | km/ h | 5 / 7 | 4.5 / 5 |
| 5.5 | Drawbar pull, laden/unladen | | N | 600 | 900 |
| 5.6 | Max. drawbar pull, laden/unladen | | N | 2000 | 2600 |
| 5.7 | Gradeability, laden/unladen | | % | 3/15 | 3/15 |
| 5.10 | Service brake type | | | Electromagnetic | Electromagnetic |
| Electric-engine | | | | | |
| 6.1 | Drive motor rating S2 60 min | | kW | 2.5 | 2.5 |
| 6.3 | The maximum allowed size battery | | mm | 740*350*620 | 740*350*620 |
| 6.4 | Battery voltage/nominal capacity K5 | | | 24 / 210 | 24 / 280 |
| 6.5 | Battery weight | | kg | 260 | 330 |
| Addition data | | | | | |
| 8.1 | Type of drive unit | | | AC | AC |
| 10.5 | Steering type | | | Electronic | Electronic |
| 10.7 | Sound pressure level at the driver's ear | | | 74 | 74 |
| 10.8 | Towing coupling, type DIN 15170 | | | Bolt type | Bolt type |

If there are improvements of technical parameters or configurations, no further notice will be given.
The diagram shown may contain non-standard configurations.

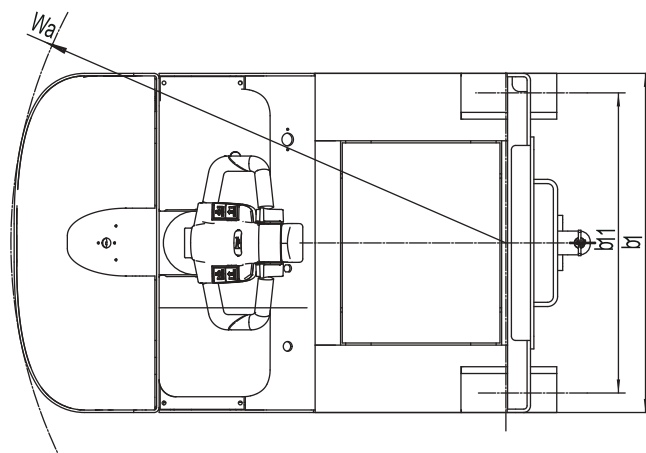
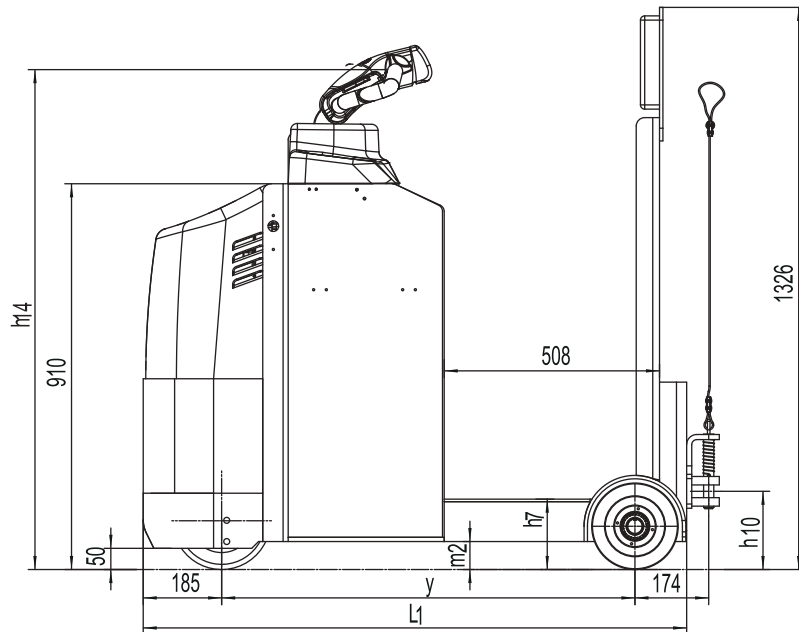

Option

| Options | QDD30S | QDD45S |
|------------------------|--------------------------|---------------|
| Driving wheel | ○Rubber wheel | ○Rubber wheel |
| Battery capacity | ○280AH/360AH | ●360AH |
| Lateral change battery | ● | ● |
| Front light | ● | ● |
| Warning light | ● | ● |
| Steering light | ○ | ○ |
| Cockpit | — | — |
| Side to pull the car | ○ | ○ |
| Note: | ● standard ○ option — NA | |